

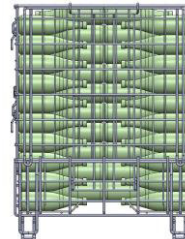

Foldable box Champagne

Tested by LNE

- > Stackable 4/1 static
- > Stackable 1/1 dynamic
- > Useful charge: 800 kg
- > Reinforced base and panels
- > ½ folding door in frontage
- > 2 plates of identification
- > Self-blocking handles
- > 500 bottles lying in line

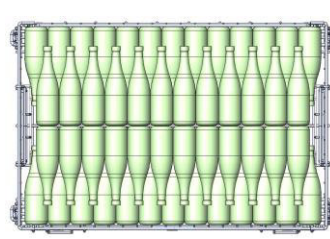

10 rows of 50 bottles (2 x 12/13)

TOTAL :
500 horizontal bottles

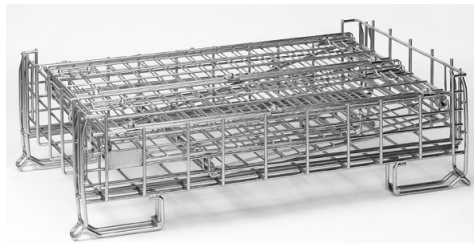

Dimensions

Ext. :	L	W	H
mm	1 246	814	1 055
Int. :	L	W	H
mm	1 155	757	924

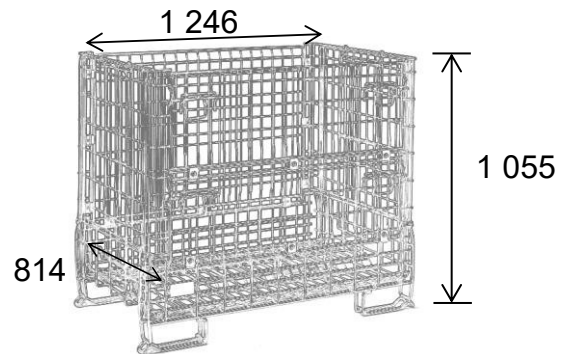

- ▶ Weight: 67,5kg approx.
- ▶ Panels mesh: 54 x 110mm
- ▶ Coating: Electrozingued CR3
- ▶ Foldable down height: 375 mm
- ▶ Wedging kit bichromated varnished

Accessories

- ▶ Label holder: for A4 format
- ▶ Cover protection
- ▶ Adapter grid kit 339 bottles 75 cl on heads
- ▶ Adapter grid kit 225 Magnum bottles horizontal

Other version

▶ Welded wedging:

- Overall dimensions (mm) : 1 252 x 799 x h 1 062
- Useful dimensions (mm): 1 158 x 748 x h 938

Full truck - 13,40
224 folded boxes



USE RECOMMENDATIONS OF FOLDABLE BOXES

- Flat floor
- The meanings of handling must be adapted (forklift operator - forks length)
- Verticality and space between piles must be respected